

Waves in space

*In an open circuit, only an electric field is detectable.
Is this because there is no magnetic field present?*

by Ivor Catt

Prior to Maxwell, a great deal of theory had been developed around electric and magnetic fields. This theory included Kirchhoff's Laws, the Biot-Savart Law and Ampère's Rule. Electrical circuits were generally steady state, or at worst slowly varying, and the problem of whether electrical and magnetic effects traversed distance instantaneously or took time to propagate did not arise.

Because fields were steady or slowly varying, experiments were generally limited to the study of closed circuits of conductors (and resistors). However, capacitors (electrolytics) were also used, and these created an anomaly in a theoretical structure which included Ampère's circuital law ($\oint H dl = i$) and Kirchhoff's second law ($\sum i = 0$). When the switches were closed, electric current flowed in the loop and (following Ampère's circuital law, also called Ampère's Rule,) magnetic flux appeared in the space around the wires.

Ampère's Rule says that if we describe a closed loop, the line integral of the magnetic field strength along the edge of the loop is related to the electric current through any surface bounded by the loop.

The capacitor created an anomaly, because a closed loop could be described where i had more than one value, depending on whether the surface (S_1) cut the conductor or S_2 passed between the plates of the capacitor. Consequently the absurd situation arose that $\oint H dl$ had to have two values at the same time.

Maxwell 'cut the Gordian Knot' by asserting that the rate of change of electric field between the capacitor plates behaved just like a real current i . So Ampère's rule became

$$\oint H dl = i + \int_s \frac{dD}{dt} ds$$

It is important to remember that the *premise* which preceded the problem of the capacitor was that electric currents and fields were steady or slowly varying. It was accepted that, at the moment the switches closed, the current i appeared at all points in the circuit. The time for the effect of the switch closure to travel across the distance from switches to capacitor was zero.

WIRELESS WORLD MARCH 1983

The current-like field dD/dt between the capacitor plates led Maxwell to conjecture that there could be electromagnetic 'waves in space'. It was already known that a changing magnetic field produced electric current (Faraday's Law $v=d\phi/dt$) and that electric current produced a magnetic field (Biot-Savart Law $H= i dl \sin \theta/4\pi r^2$.) The changing electric field dD/dt seemed to be an electric current in space. With both changing magnetic fields and changing electric

currents in space, we seemed to have the possibility of wire-less propagation of electromagnetic signals using a crabwise progression of cause and effect; electric current \rightarrow magnetic field \rightarrow electric current

The error in this whole business occurred right at the start. Let us assume that the conductors linking battery to capacitor are one light year long. When the switches are closed, it is obvious that current will not immediately flow in the capacitor. A wave front must travel from switches to capacitor, and behind that front will be electric field and magnetic field – we have a transmission line. Also, should the distance between the two conductors or their shape change, some of the wave front will continue to the right and some will reflect to the left, carrying back the message about the change.

The front end of the capacitor is merely one such change in the cross section of the transmission line. The far (open circuit) end of the capacitor is another such change.

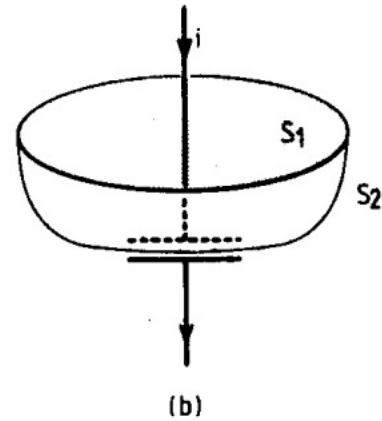
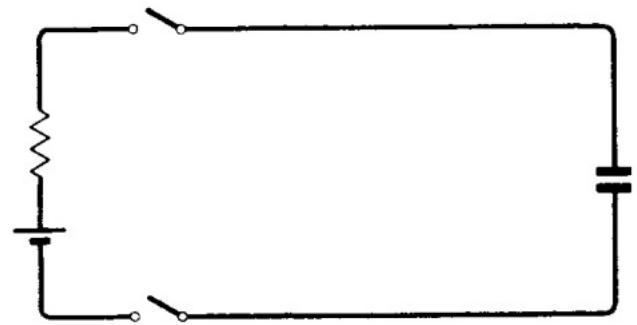

Fig 1. The elemental closed loop (a), in which the capacitor creates the difficulty that the current must have two values, depending on whether the surface (b) cuts the conductor or bisects the capacitor.

The problem Maxwell should have been concerned about was how the electromagnetic field developed between the wires when the switches were closed, not what happened in a capacitor. The transmission line problem (AB) precedes the capacitor problem (CD), and the capacitor problem would be solved automatically with the solution of the transmission line problem.

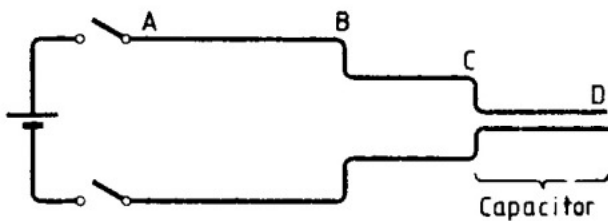

Fig 2. A changing separation between conductors reflects energy. The capacitor is simply another change.

Before the switches are closed, we can measure a voltage and electric field but find no trace of a magnetic field. When the switches are closed, an electric current starts off down the wires and a magnetic field begins to appear between the wires. The conclusion that the voltage (or pressure) causes the electric current which in turn causes the magnetic field is compelling, and it is not surprising that this mistaken view has lasted for a century. It is then a short step to say that the changing magnetic field in its turn (by Faraday's Law) generates an electric field and thence a (displacement) current, and the sequence can start again.

But was there *really* no magnetic field before the switches were closed?

Let us consider a steady charged capacitor. Does it have no magnetic field, only an electric field? In order to understand the situation in the battery and wires up to the switches before they are closed, it is useful to study the reed-relay pulse generator.

The reed relay pulse generator was a means of generating a fast pulse using rather primitive methods. A one metre section of 50 ohm coax. AB was charged up to a steady 10 volts (say) via a one megohm resistor, and then suddenly discharged into a long piece of coax. BC by the closure of two switches.

A five volt pulse two metres wide was found to travel off to the right at the speed of light for the dielectric on closure of the switches, leaving the section AB completely discharged.

(The practical device lacked the second, lower switch at B, which is added in the diagram below to simplify the argument.)

The curious point is that the width of the pulse travelling off down BC is twice as much as the time delay for a signal between A and B. Also, the voltage is half of

what one would expect.

It appears that after the switch was closed, some electromagnetic energy must have started off to the *left*, away from the now closed switch; bounced off the open circuit at A, and then returned all the way back to the switch B and beyond.

This paradox, that when the switches are closed, electromagnetic energy promptly rushes *away* from the path suddenly made available, is understandable if one postulates that a steady charged capacitor AB is not steady at all; it contains electromagnetic energy, half of it travelling to the right at the speed of light, and the other half travelling to the left at the speed of light.

Now it becomes obvious that when the switches are closed, the rightwards travelling electromagnetic energy will exit down BC first, immediately followed by the leftwards travelling electromagnetic energy after it has bounced off the open circuit at A. Even before the switches were closed, every segment of electric field had coexisting with it a segment of magnetic field at right angles, and both were travelling together at the speed of light.

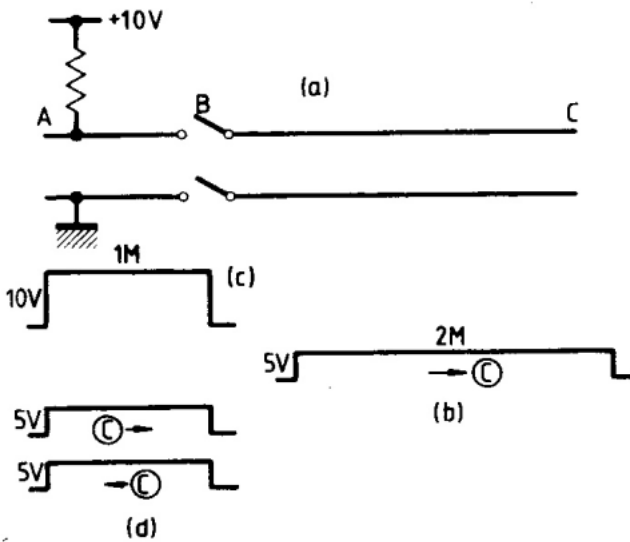

Fig 3. Pulse generator (a). Changing AB to 10V and closing switches produces 5V pulse twice as long as AB (c) and (d), caused by left and right travelling pulses following down line BC.

What is true of a 'steady' charged capacitor or coax. cable is also true of a pair of wires connected to the battery. Before closure of the switches, electromagnetic (not electric) energy was oscillating to and fro between battery and switches. Since the same amount travelled in both directions, the magnetic fields being equal and oppo-

site cancelled, and only an electric field could be detected. 'Waves in space' existed between these two wires long before the switches were closed and before the capacitor came into the picture. WW

DEATH OF ELECTRIC CURRENT

I have progress to report.

D. W. Bell, who is not given to wasting words, said in his letter (October 1982) that the role of mathematics in physics "is essentially *predictive*" and concluded his letter "But if one accepts the logic of mathematics, one can accept the logic of mathematical models." It is clear from the introduction to his paper that Hertz would have agreed with Professor Bell; in fact Bell has explained the motive for every experiment performed by Hertz between 1886 and the time of his untimely death on the first day of 1894 at the age of 36. By accepting the logic of Maxwell's mathematical model of an ether, Heaviside and Poynting were the first scientists to realise that Maxwell's equations predict that the source of a current in a wire was located in the surround-

ing field. Hertz agreed with the mathematical reasoning of the Heaviside-Poynting theory "as the correct interpretation of Maxwell's equations."

Catt's critics, although not accepting the logic of Maxwell's mathematical model, have all based their criticism on the fact that Maxwell's equations predict the phantom existence of his displacement current. Maxwell's own definition of his displacement current is in Art. 111 of his Treatise, dealing with the phenomenon of induction of electricity through non-conductors.

"Electric Displacement. When induction is transmitted through a dielectric, there is in the first place a displacement of electricity in the direction of the induction. For instance, in a Leyden jar, of which the inner coating is charged positively, and the outer coating negatively, the direction of the displacement of positive electricity in the substance of the glass is from within outwards.

Any increase of this displacement is equivalent, during the time of increase, to a current of positive electricity from within outwards, and any diminution of the displacement is equivalent to a current in the opposite direction."

In other words, only during an acceleration or deceleration of the velocity of electric displacement does Maxwell's displacement current manifest itself. Maxwell said in Art. 62 that all electric currents flow in closed circuits, and in Art. 305 that as all currents of conduction must flow from a high to a low potential, conduction currents cannot flow in closed loops. I have suspected that all current loops are closed, and more importantly caused by, a displacement current, for instance in the induction of electricity from the primary to the secondary winding of a transformer. Hertz's paper seems to confirm this is so. The present confusion in electromagnetic theory lies in our failure to differentiate between electric displacement and displacement current; the latter only manifests itself when the momentum of the former either accelerates or decelerates.

Ivor Catt's Heaviside Signal or Poynting Vector travels through space at the constant velocity of light, and is therefore by Newton's first law of motion, inert. It is a form of perpetual motion, and will travel through space at its constant velocity forever, unless acted upon by a polarized force. Newton defined inertia as a 'latent' or potential force. If a body at rest or travelling at a constant velocity is either accelerated or decelerated, its equal and opposite reaction to a polarized force causes its latent force to be transformed into an active force, because a force is the product of a mass and an acceleration or deceleration. Maxwell's electric displacement also travels through his ether at the constant velocity of light in free space in the form of a wave of displacement or strain of his ether, and like the Heaviside Signal, will do so forever unless a polarized force, such as a conductor, decelerates the electric displacement and changes it into a displacement current. When the displacement of the potential energy of the ether is accelerated from a state of rest to the velocity of light, the resultant strain is in the form of a displacement current during the period of accelera-

WIRELESS WORLD APRIL 1983

tion. When a wave of electric displacement of the intensity of the ether's potential energy suffers a deceleration after its flight through space at a constant velocity, the electric displacement's kinetic energy is transformed into an electromotive force which produces a displacement current. The e.m.f. causes a displacement current to penetrate the surface of a conductor of electricity, say an aerial.

In the case of very-low-temperature superconductivity, I believe Maxwell's equations and his mathematical model predict that the wire presents an impenetrable barrier and perfectly frictionless surface of slip to the electric displacement in the neighbourhood of the wire, and the current is inert and flowing in a closed loop at a constant velocity in the surrounding field only. As the temperature of the wire increases, the wire's surface loses its properties, and the reactive centripetal force of the surrounding ether aimed at the centre of the wire, decelerates the momentum of the electric displacement by forcing it to penetrate the surface of the wire, producing a displacement current in the wire. The permittivity, or modulus of electric elasticity of the ether surrounding the individual atoms of the mass of the wire must decrease as the wire's temperature increases. The flow of heat is a form of displacement current.

Hertz's paper raises many questions which are sure candidates for the immediate application of Dr Murray's Doctrine of the Improper Question. If a current of conduction is caused by the penetration into the wire by displacement current, is the current when steady, travelling at a constant velocity longitudinally through the length of the wire, or, as Maxwell's equations predict, acting vertically through the surface of the wire only?

Should we call the electric current in a conductor the Catt Effect?

M. G. Wellard
Kenley,
Surrey

I refer to the letter from Mr Ivor Catt in the *WW* for February 1983. He asked me to look at his diagram on p.80 *WW* December 1980. I have now been able to do this, courtesy of the *WW* reprint service.

It has taken me several days (and sleepless nights) to see what was in his mind, and do not mind admitting I got off to what I think was a false start in what I intended to say by reply, because I think he has made a mistake in what he invites me to do. So if he does not mind I am going to do two things my way.

Firstly, that 50ohm bit that he wants to put in the upper plate; I am going to do so loosely, so that it can be removed without touching it, by means of a sudden surge of gravity, or a puff of wind, or an angel on wings, so that whatever portion of the total charge is residing on it goes with it, leaving a gap in the surface. What was one charged capacitor is now two smaller ones, each carrying less than half the original charge.

Secondly I am not, in the interests of simplicity, going to use a length of coax., but rather to employ two parallel conductors of a spacing which entitles them to the nominal qualification of 50ohms, erected in the way he asks for. What have I got now? No more or less than two terminal posts, one for each capacitor, each of the same sign and potential.

We can do as we please in the way of rearranging these charges from external sources.

What we have not got is a pair of conductors so placed and utilized that they can be said to be exhibiting a Z of 50 ohms to any external influence. So they are not by my reckoning an accurate substitute for the 50ohm resistor we got the angels to take away.

What I will join in and say, is that of course in charging and discharging these two capacitors, or the original one for that matter, at the velocity of light or thereabouts we do have a time lapse from terminal to the most remote part of the conducting surfaces concerned, which does not help me to consider the behaviour of frictionally induced charges on insulators.

O. Dogg
Hurstpierpoint,
Hussocks,
West Sussex.

WIRELESS WORLD APRIL 1983

C.A.M.

117

HERETICAL PHYSICS

Those of us who are approaching the age of 80 can hardly bear to wait a month to find out what kind of Newer Physics is going to turn up in the *WW* "Letters". Some of the ideas are so oddly fascinating that it seems a real pity that they cannot all be right.

Attractive though this is, I cannot help remembering the professor of physics who reminded his students that what happened on the lab. bench was real, whereas what went on inside human heads was mostly fantasy, and often pathological fantasy at that.

P. C. Smethurst,
Bishop's Stortford, Herts.

WAVES IN SPACE

Ivor Catt (March, 1983) says "the voltage is half of what one would expect". The curious point to me is on what he bases his expectations. If the charged line is regarded as a voltage source of impedance Z_0 (the characteristic impedance) connected to another impedance Z_0 through the switches, as in the accompanying sketch, then the voltage is exactly what one would expect. The finite duration of the pulse stems from the fact that the charged line is an energy storage device (electrostatic field) and not a source of e.m.f. which implies energy conversion. It is worth adding that the impedance technique also enables one to predict occurrences when the Z_0 of the long line is not equal to that of the charged line.

As to the claimed paradox that "electromagnetic energy promptly rushes away from the path suddenly made available", if Mr Catt will

examine Poynting's vector in the charged line after the switches are closed, he will find that the electromagnetic energy moves only into the long line, that is, from left to right.

It is possible to regard the condition of the charged line as the result of interference between two waves travelling in opposite directions, just as one can treat a straight line as the arc of a circle of infinite radius. There are times when they are useful models of reality. The real paradox of the article is the question of where Mr Catt (and, for that matter, *Wireless World*) have been all this time. To my knowledge, the Royal Air Force used this approach to transmission lines as pulse generators in 1959, and I have no doubt that the technique goes back much further in time.

R. T. Lamb
British Telecom
Milton Keynes

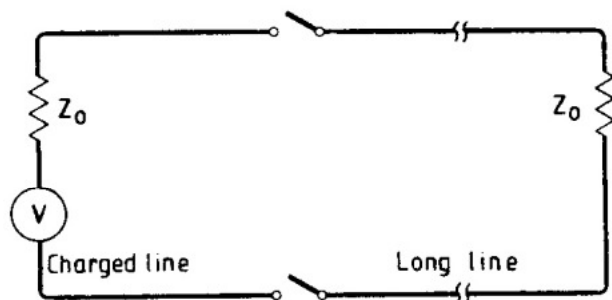

I refer to Mr Catt's article in the March 1983 issue.

In a letter, I could not hope to reproduce the great body of scientific and engineering knowledge that has amply demonstrated the non-relativistic interpretation of Maxwell's Equations or of Einstein's treatment using special relativity. If the theory is so seriously flawed it is surprising that we can design and build antennas and microwave devices. Nevertheless, I cannot let Mr Catt's analysis of the pulse generator go unchallenged, especially as it is so easy to demolish his arguments.

Firstly, if a piece of charged coax. really has equal and opposite waves running in each direction why are they not attenuated by the losses in the line? After all in one second each of his waves would have travelled nearly 2,000 miles in lossy coax.

Secondly, if I connect an antenna to a piece of coax. I can still charge up the line. Why do not these waves of which he speaks radiate into space? Or, at least, the high-frequency components of the pulse to which the antenna will be matched.

The conventional solution to his 'exotic' problem can be found by solving the transmission line equations for a cable under the stated starting conditions (see reference). As this is rather tedious and since Mr Catt seems to prefer hand waving to mathematics I will at least demonstrate where the 2m pulse length comes from.

When the extra length of line is connected to the 1m line, charge starts to move down the new line charging the distributed capacitance of the line through its distributed inductance as it goes. (Maxwell's equations applied to circuits show us that capacitors connected together share their charge). This leaves a void which the 10V (1m) line fills. The void propagates towards the open end of 1m line at the speed of the line. The charge close to the open end of the line will be liberated at a time equivalent to 1m of line and will take 1m to propagate to the other end, explaining the 2m length of the pulse.

The pleasing aspect of the above argument is that we do not have to destroy a century of successful electro-magnetic theory to produce it. If Mr Catt has so much more insight into electro-magnetic theory than the rest of us it is surprising that he has not produced any new microwave devices that demonstrate his superior understanding.

Timothy C. Webb
Columbia, MD
USA

Reference: Brown and Glazier: Signal Analysis pp. 345-349.

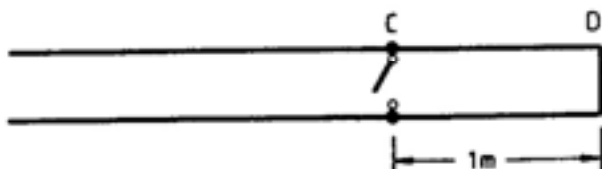

Fig. 1.

I was not too sure whether I should be amused or startled by Ivor Catt's article on "Waves in Space" in which he postulated the existence of electromagnetic energy in a static electric field, when I reminded myself that the date was 1st April. It had never occurred to me, even remotely, that a magnetic field could be directly caused to exist by the presence of an electric field. However, being sympathetic to the idea that all things appear to be possible in this day and age, I allowed my mind to be bent a little further and read on.

The production of a voltage pulse in a transmission line which is half the amplitude and twice the length of that existing statically in a piece of coaxial cable, can form the basis of a number of interesting experiments. For example, Mr Catt's travelling pulse can be converted back into a static charge again if his coaxial cable is terminated into an open circuit but with a pair of switches 1 metre from the end as shown in Fig. 1. When the switch at B is closed and the resulting pulse eventually reaches D, it will of course, be reflected (double back on itself); however, if switch C, is opened at the instant the leading edge meets the trailing edge, no great drama ensues but we are left with a 1 metre piece of statically charged coaxial cable as before. It is also interesting to consider what happens if point D is terminated into a short circuit. This time, the pulse will be converted into one of twice the current at zero voltage and the leading and trailing edges will be locked together and oscillate back and forth converting the pulse between a current at zero voltage and a voltage at zero current until this activity decays due to losses.

However, perhaps it would be more interesting to consider what would happen if this final 1 metre of coaxial cable is made superconducting and instead of isolating switches at C, a short circuiting switch is provided as shown in Fig. 2. If the switch at C is closed at the instant the leading and trailing edges meet, electrons at zero voltage, will continue to flow around the 1 metre coaxial circuit as a direct current. It would, perhaps, be better to say that current drifts around, because depending on the construction of the coax., it could take hours for any single electron to work its way around the circuit. It should, of course, be remembered,

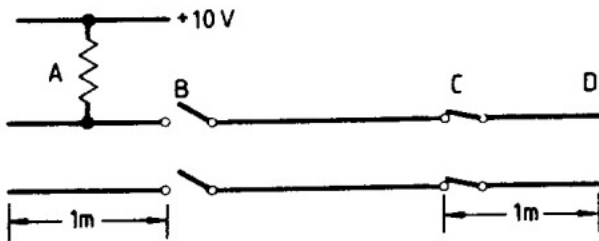

Fig. 2.

that as no voltage is present, the density of the electrons in the closed circuit is the same as that in the remainder of the uncharged transmission line.

Unless someone comes along and throws into doubt that an electric field exists between adjacent electrons and protons it is easy to demonstrate that in the above circuit condition, countless billions of electric fields exist alongside the magnetic field caused by the current, although no measurable voltage exists. Similarly in the case of the purely electrostatic condition, the same large number of magnetic fields exist due to the rotating and spinning electrons. However, I doubt somehow whether this has anything to do with the way the charged section of coaxial cable propagates a pulse whose length is twice that of the charged section. And I must confess, that the prospect of opposing magnetic fields oscillating back and forth along the cable as Mr Catt suggests, appears to be even less likely.

Surely, the answer to his paradox is simply that on closing the switch at B, the electrons that flow out of the negatively charged conductor and those that flow into the positive conductor of the cable not only cause a wave front of current and voltages to be transmitted along the line but also back into the charged section itself. And since the energy has to be shared between both fronts, the voltage will be halved. The discharging current flowing into the charged section will set up a magnetic field, which, on collapsing, will produce an equal pulse of voltage and current to follow on the heels of the pulse which has already departed from the originally charged section.

R. J. Hodges
Bath
Avon

DEATH OF ELECTRIC CURRENT

I believe Ivor Catt bases his theory on Heaviside's "the current in the wire is set up by the energy transmitted through the medium around it."

Chapter ten of Hertz's book 'Electric Waves' is a reprint of his paper 'On the Propagation of Electric Waves by Means of Wires' first published in 1889, a year after the experiments which made him famous. The purpose behind the experiments described in this later paper was to test Heaviside's and Poynting's theory that, as Hertz wrote, "the electric force which determines the current is not propagated in the wire itself, but under all circumstances penetrates from without into the wire. . . ." Hertz went on to say "As a matter of fact the theory was found to be confirmed by the experiments which are now to be described; and it will be seen that these few experiments are amply sufficient to support the conception introduced by Messrs Heaviside and Poynting."

Hertz then described a set of experiments which used his invention of the coaxial cable and the balanced feeder or transmission line, and concluded his paper, "On studying the experiments above described, the mode in which we have interpreted them, and the explanations of the investigators referred to in the introduction, one difference will be found especially striking between the conception here advocated and the usually accepted view. (Weber's theory of electricity carried by charged particles acting instantaneously at a distance.) In the latter, conductors appear as the only bodies which take part in the propagation of electrical disturbances — non-conductors as bodies which oppose this propagation. According to our conception, on the other hand, all propagation of electrical disturbances takes place through non-conductors; and conductors oppose this propagation with a resistance which, in the case of rapid alterna-

tions, is insuperable. We might almost feel inclined to agree to the statement that conductors and non-conductors should, according to this conception, have their names interchanged"

Hertz was even more specific in his Supplementary Note No. 24. "By the experiments in the following paper it is pretty plainly proved that in the case of rapid variations of current the changes penetrate from without into the wire. It is thereby made probable that in the case of a steady current as well, the disturbance in the wire itself is not, as has hitherto been assumed, the cause of the phenomena in its neighbourhood; but that, on the contrary, the disturbances in the neighbourhood of the wire are the cause of the phenomena inside it."

Catt's critics have a choice: either Hertz was a crank and a crackpot, or he was, as an experimenter and detective, in the same class as Faraday. If Hertz's diagnosis of his experiments with a transmission line is correct, the effect we call a current is caused by "the disturbances in the neighbourhood of the wire," what, in the neighbourhood of the wire, is being disturbed? Maxwell's ether?

M. G. Wellard
Kenley Surrey

WAVES IN SPACE

I refer to the correspondence in the August issue concerning Catt's "Waves in Space", (March, 1983).

Ivor Catt has, for some years, been proposing new explanations of electrical phenomena which many regard as already fully explained by classical e-m theory; theory which unfortunately has become dogma because few have bothered to question its tenets in those areas where its teachings give rise to curious and unexplained paradoxes.

Correspondents who try to put Catt down generally throw up a dogmatic smokescreen whilst often failing competely to address themselves to the apparently paradoxical events he has attempted to explain. The latest correspondence concerning "Waves in Space" is no exception. R. T. Lamb's letter gives no real expla-

nation of the phenomena that Catt discussed and simply fluffs the issue of pulse duration with a remark about the charged line being an energy storage device rather than a source of e.m.f.

Timothy C. Webb's letter puts a finger on one important issue when he asks why Catt's contra-moving waves are not destroyed by line losses, but he fails to ask whether conventional energy dissipation due to line loss applies to these contra-moving waves. I suspect Catt thinks otherwise and it would be interesting to have his views.

In other respects Mr Webb's letter falls into the dogma trap. There is a resounding bit about

"The great body of scientific and engineering knowledge that has amply demonstrated . . ." etc., etc. Dr Catt has quite reasonably asserted that the great body of scientific and engineering knowledge has singularly failed amply to demonstrate some of the things it purports to explain! At the end of his letter Webb gives what I found to be an incomprehensible explanation of the pulse duration problem and then rounds this off with a remark about the "pleasing aspect of this argument . . ." etc. I was not very pleased because I could not make head nor tail of it!

Hodge's letter is perhaps more thoughtful but again it does not seem to explain the phenomena which Catt discussed in his article.

Catt's theories may be wrong but he is certainly right to shine lights into some of the dark and deceiving corners of classical e.m. theory. One would like to see more reasoned arguments advanced in refutation and less reliance on the "dogma must be right" approach which, incidentally, rather neatly mirrors the discussion on the "closed loop arguments", (said to be used to support relativistic dogma), given in an unrelated letter from A. H. Winterflood in the same issue of *Wireless World*.

Anyone who thinks he knows all about electricity should also read Professor Jennison's article on making a charge from a radio wave!

M. G. T. Hewlett
Midhurst
W. Sussex

DEATH OF ELECTRIC CURRENT

Two quotations from *Wireless World*, September 1983:

1. M. G. Wellard's letter, quoting Hertz: "In [Weber's theory], conductors appear as the only bodies which take part in the propagation of electrical disturbances – non-conductors as bodies which oppose this propagation. According to our [Hertz's] conception . . . all propagation of electrical disturbances takes place through non-conductors; and conductors oppose this".

2. M. McLoughlin: "Current dumping review – 1": "Obviously high farce has effected an entry . . . A complex situation may sometimes be viewed quite validly in alternative ways. In this case the fullest understanding seems to be obtained when one has seen both explanations, seen that they are both valid, and grasped that they are complementary views of the same situation".

Need one say more?

R. Kennaway
Norwich